



LIC#984612
13455 Ventura Blvd. Suite#215
Sherman Oaks, CA 91423
Tel:818-933-0750
Fax:818-933-0760

Bid #-6657

June 18, 2019

Name – TAS schools.

Address- 4000 S Main street Los Angeles CA 90037

Attention- Tom Nizetich

Proposal for new lobby entrance:

Demolition: <ol style="list-style-type: none">1. Demolition of 2 walls in the new file room.2. Cover and protect all flooring.3. Haul away all construction debris from job site.	\$2,750
HVAC: <ol style="list-style-type: none">1. Relocate air ducts according to new layout with 2 new registers.	\$2,800
Framing: <ol style="list-style-type: none">1. Create new opening for window and install the window we took out from few file rooms on guards room.2. Build new solid wall between new lobby to room 146B.3. Close 2 windows in file room.4. New opening for 2 tellers windows between 138B to 139B.	\$2,900
Electrical: <ol style="list-style-type: none">1. New switches and walls outlet to be cancel / relocate according to the new floor plan.2. Separate light between new lobby to back room with new switch3. Relocate light fixture as needed.	\$2,850

13455 Ventura Blvd Suite 215 Sherman oaks CA 91423
Phone (818) 933-0750 Fax (818) 933-0760



LIC#984612
 13455 Ventura Blvd. Suite#215
 Sherman Oaks, CA 91423
 Tel:818-933-0750
 Fax:818-933-0760

4. All electrical to be per code.	
Drywall and paint: 1. Install new x type drywall on all affected areas. 2. Paint all effected areas with paint to match existing.	\$2,900
Flooring: 1. Repair flooring on all affected areas from walls removal. 2. Install new vinyl base molding to much existing on all affected areas. 3. Owner to supply flooring.	\$1,150
Suspension ceiling: 1. Repair all necessary suspension ceiling according to the new walls and new layout. 2. Ceiling to match existing.	\$2,935
1. Install teller windows according to the attached model and specs (see attachment).	\$1,500
Teller bulletproof windows T1 36" BY 36") supply by Eden Development	\$2,950
Teller bulletproof windows T1 36" BY 36") supply by Eden Development.	\$2,950

Eden Development:

13455 Ventura Blvd Suite 215 Sherman oaks CA 91423
 Phone (818) 933-0750 Fax (818) 933-0760



LIC#984612
13455 Ventura Blvd. Suite#215
Sherman Oaks, CA 91423
Tel:818-933-0750
Fax:818-933-0760



Eden Development

13455 Ventura Blvd Suite 215 Sherman oaks CA 91423
Phone (818) 933-0750 Fax (818) 933-0760



June 16, 2019

Mr. Tom Nizetich
Director of Facilities
Accelerated Schools
Los Angeles, CA

Dear Mr. Nizetich.

On behalf of McMurray Stern, we would like to thank you for allowing us to present our quotation for a new Spacesaver high-density mobile storage system that is designed to help you make maximum use of the floor space in the Accelerated School's future renovated records room space.

With our proposal, we are committing all our resources and experiences gained over the past 38 years. We value the opportunity to fulfill the scope of responsibility that you have outlined for us.

If you have any questions regarding this proposal or our ability to serve you, please call. Again, thank you for your consideration.

Sincerely yours,

Brent J. Sheffield
Senior Design Consultant
McMurray Stern
Santa Fe Springs, CA



WHY MCMURRAY STERN?

The McMurray Stern team is comprised of 50 professionals that serve you at each step of the process - design, estimating, order entry, logistics planning, installation, training and service. Each team is responsible for making sure your experience with McMurray Stern is a positive one. Our mission statement is clear - to serve YOU our customer with the best of our abilities and enable our team to exceed your project's requirements and timeline.

McMurray Stern has been serving southern California since 1980 in the development, implementation and service of Spacesaver filing and storage systems. We are the largest full-service filing and storage systems company in California. Our 18 full-time, factory-trained Spacesaver installation and service professionals have an average of 10 years' experience with our company. Our team has completed over 10,000 installations of Spacesaver mobile shelving systems and have thousands of satisfied customers who also employ us to consult for records management solutions barcode tracking systems, on-demand labeling systems, filing system design and filing system supplies.



McMurray Stern is a certified licensed contractor. California contractor's license # 469217.

WHY SPACESAVER?

Spacesaver Corporation has over 100,000 installed systems - more than all of their competitors combined. With over 30 years of manufacturing experience, 28 patents for product engineering and safety systems as well as 350 dedicated professionals, their team has "set the bar of excellence" in the mobile shelving industry. Your system will have structural components that will give you decades of performance as well as the most state-of-the-art electronics, programmability and integrated safety systems available.

Spacesaver Corporation is proud to have reached the level of ISO-9001 certification. This ensures that your equipment meets the highest quality standards and guarantees the longevity of your investment.



McMurray Stern has thousands of Spacesaver filing and storage installations locally that will verify the completeness, professionalism, and product quality of our systems. Your Design Consultant can arrange a tour of a local installation, so you can see how we have helped companies similar to yours solve their storage dilemmas.

Spacesaver mobile system description

We are proposing to furnish and install one new legal size, high density mechanical assist mobile system as manufactured by Spacesaver Corporation. This system is designed to last for several decades of full use.

The Spacesaver mobile system can be further outlined as follows:

- 1) Three double moveable shelving carriages, each 7'-0" long x 24" deep x 76" high with 7 shelf openings.
- 2) One single moveable shelving carriage 7'-0" long x 15" deep x 76" high with 7 shelf openings
- 3) One mobile system aisle, 48" wide.
- 4) One pull-out reference shelf per aisle.
- 5) One security lock on the single moveable carriage that also includes back panels.
- 6) Furniture grade file shelving with closed shelving uprights and two file supports per shelf.

Our proposal also includes one scheduled service call to be made during the first year of operation.

The total capacity of this Spacesaver system is 4,116 linear filing inches and this is the equivalent of twenty-three (23), 36" wide, 5-drawer lateral file cabinets.

Total Investment

The total investment for the Spacesaver medium duty mechanical assist mobile system outlined above including freight, installation and applicable taxes is **\$17,468.00 (Seventeen-Thousand, Four-Hundred and Sixty-Eight Dollars)**

Our standard payment schedule is the following:

50 percent with the order

50 percent upon completion.

The current manufacturing lead-time for the Spacesaver system is 10-11 weeks after receipt of an order and the actual installation will take two working days.

The State has determined that any person who purports to have the capacity to undertake or submits a bid to construct these types of structures must be licensed pursuant to Contractor's License Law (B & P Code, Division 3, Chapter 9).

Please note critical dimensions. McMurray-Stern is not responsible for deviations from critical dimensions shown. Customer and/or contractor to adhere to critical dimensions. All dimensions within DIM symbol are critical Dimensions.

Filing Capacity	
Option1 WH	
Actual LFI	3,920"
Nominal LFI	4,116"
Actual LFF	326'8"
Nominal LFF	343'0"
<input checked="" type="checkbox"/>	Include Existing

15511 Carmenita Road
Santa Fe Springs, CA. 90670
phone (562) 623-3000
fax (562) 623-3039
www.mcmurraystern.com

These drawings and design concepts are the property and copyright of McMurray-Stern and shall not be copied, used or reproduced in whole or in part except by written and compensated agreement with McMurray-Stern.

General Notes:

- McMurray - Stern, agrees to install in a free and clear area as defined on approved drawings. Adequate unloading facilities with unlimited access to the installation area. Building elevator and unloading dock shall be provided by customer.
- All systems and/or shelving sold by McMurray-Stern require the use of anchors by pre-drilling into the existing floor. It is the users responsibility to supply a copy of this drawing to whomever takes responsibility for the building and any wiring, plumbing, etc. which could possibly be damaged by this process. Any information pertaining to such concerns must be provided to McMurray-Stern prior to the start of work. Contact your Design Consultant in regards to any questions which may arise.
- Owner/General Contractor is responsible for coordinating floor covering installation after McMurray-Stern installs system rail & floor.
- Surveys, permits, and regulations: Buyer shall procure and pay for all permits and/or inspections required by any governmental authority for any part of the work performed by McMurray-Stern, except as otherwise stated.
- Testing: All material and equipment for testing the installation or anchors shall be provided at the buyers expense.
- Floor construction: Slab on grade
- Shelving type: 4post Color: -
- Due to individual customer preferences and requirements, if adjustable dividers are ordered, they will be supplied in bulk and installed on shelves by end user.
- Client is responsible for the load bearing capacity of the floor upon which the proposed installation shall be constructed. A floor loading evaluation by a licensed structural engineer can be provided for an additional fee.
- (If Applicable) OSHPD Pre-Approval (OPA) Anchorage Specifications are preliminary, pending the site specific calcs from the engineer.

Accelerated School
116 East Martin Luther King Blvd.
Los Angeles, CA 90011

Date: 01/18/19 Drawn By: m
Project No: 27873 Job No: xxxxxx
Consultant: BS

Date:	Revision	By	No.
03/06/19	Changed from MA to WH.	JG	1
00/00/00	-	-	-
00/00/00	-	-	-
00/00/00	-	-	-
00/00/00	-	-	-
00/00/00	-	-	-

Scale: 3/16" = 1'-0" Sheet: **1 of 1**

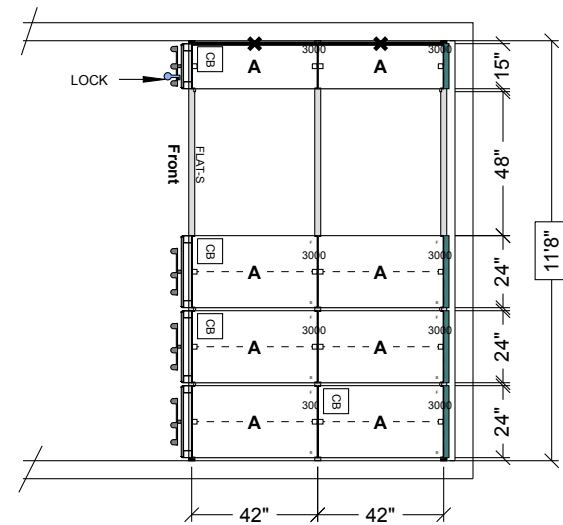

PRELIMINARY - PLAN VIEW
OPTION 1 - WH

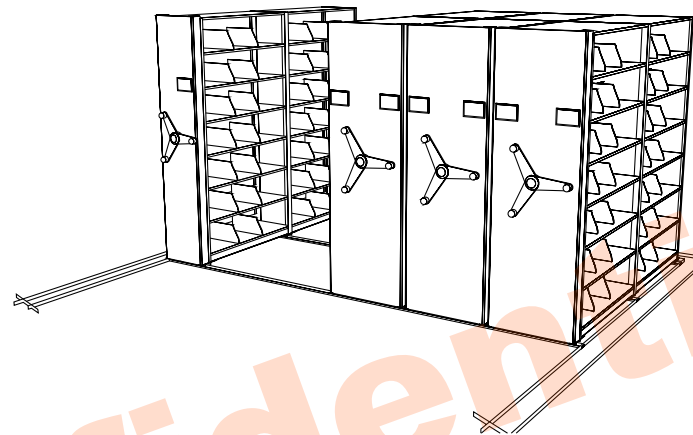

3D VIEW

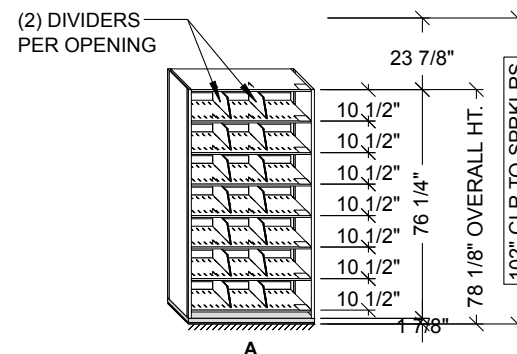

PRELIMINARY - ELEVATIONS

X = METAL BACK PANEL

NOTE: ALL ROOM DIMENSIONS MUST BE FIELD VERIFIED.

Confidential
 McMurray Stern
 © 2019